

**Aim:** This is a three week module with the third week being an excursion. The purposes of these sessions are to learn about pet care and complete a community service building project. Most girls are keen on pets and animals so raising interest in this topic should not be a problem, however be mindful of the fact that some girls may have a fear of a particular type of pet e.g. dogs, mice, horses.



### Objectives

During this three week unit we will:

- Introduce the girls to building and using a range of workshop tools.
- Complete a service project for the local community; building a bird feeder or rabbit/ guinea pig hutch.
- Meet experts in pet and animal care (e.g. vet, SPCA member, pet shop owner, dog groomer, horse groomer, police dog handler, Dog Obedience School trainer, pet enthusiast or breeder of rabbits, birds, horses ...)
- Visit a location such as a farm or wildlife sanctuary where the girls will come in contact with animals/ pets and see how others care for these animals.

Possible excursions: go horse riding; visit a farm, an aviary or a wildlife sanctuary or bird colonies, or contact DOC to find out about bird release projects). See Week 3 for other excursion ideas.

### Prior preparation:

When inviting guest speakers in or visiting a site, arrangements need to be made a few weeks prior to the event.

Building materials and tools need to be collected before Week 1. See instructions and materials at the end of these session outlines. The instructions for the bird feeder come from the following website

[www.lowes.com/lowes/lkn?action=howTo&p=Build/ScrapsForTheBirds](http://www.lowes.com/lowes/lkn?action=howTo&p=Build/ScrapsForTheBirds)

Make a model of the bird feeder or hutch that the girls will be building.

### Equipment

Scraps of wood for practicing building techniques e.g. hammering and sawing  
Saws and hammers enough for each group.

Saw horse or bench mate

Plus materials as listed for the project chosen.

The project is to build a bird feeder or a rabbit/guinea pig hutch for a playgroup, kindergarten or rest home. Try to find a group that will benefit from this community service project or donate it to the SPCA.

- The girls will learn building skills such as hammering a nail in correctly and sawing a plank of wood with a hand saw.
- A fun activity for some of the girls while the others are building their group project is to get a sawn log and have a competition - how many hits to get the nail into the wood. The least number of hits is the winner. Points or prizes can be given to the winner.
- During the building project invite experts in from the community to talk about pet care e.g. Vet, SPCA member, dog groomer, breeder or pet enthusiast.



Another alternative project is making toys for mice or rats (e.g. ladders, wheels) or toys for kittens and puppies - see your local pet shop for ideas.

**Pre SetUP arrival time: 5 minutes**

Have balls and sports equipment available for the girls to play with as they arrive prior to the formal part of the programme.

**PreSet up Games: 10-15 Minutes**

Using the games at the back of this resource, introduce, demonstrate and play an indoor game, which will involve the whole group and has lots of action. One leader can run this satisfactorily while other leaders are preparing for the evening's activities.

**SetUp: 10minutes:** The "SetUP" is the formal start to the evening's programme when the teams will come together for opening prayer, roll call etc. Assemble in the Home Zone.

**Devotions:**

**Building a House:** (Courtesy of BB God-on-line)

**Visual Aid**

Take along a variety of construction materials and divide the girls into groups. Give each group different equipment from the others. Get each group to build a miniature house. Equipment could include: Lego, blocks, toothpicks, straws, ice

cream sticks, dough, cotton reels and of course some suitable things to stick the houses together such as blu-tack, glue, tape, plasticine, pins and so on.

### **Introduction**

Make a small house using the equipment provided. You have five minutes to construct your house.

### **Progression**

When someone builds a house, they have to consider several different things. They have to consider firstly, where they'll build it. *Why is the location of a house important? What things would a builder need to consider about the location? A builder would also need to consider what materials they are going to use. Why does it matter what materials would be used? What things would the builder need to consider about the materials? If you could choose what kind of foundation this house you've built now would rest on, what would you choose? Why?*

### **Bible Reading**

Anyone who hears and obeys these teachings of mine is like a wise person who built a house on solid rock. Rain poured down, rivers flooded, and winds beat against that house. But it did not fall, because it was built **on solid rock**.

Anyone who hears my teachings and doesn't obey them is like a foolish person who built a house on sand. The rain poured down, the rivers flooded, and the winds blew and beat against that house, finally it crashed.

(Matthew 7:24-27 CEV Bible)

### **Application**

Firm foundations are needed when building a house. You can't just build a house anywhere. Even if you use the best materials you can possibly find, if you build your house on sand, the water will wash the sand away, and your house will crash!! That's like us. We need firm foundations. Jesus' teachings give us a firm foundation to our lives. If we listen to these things and try and make them an important and real part of our every day, we will be building our lives on a firm foundation. Our lives will not crash like the house on the sand that the foolish man built. That's not to say we won't experience the rains, the rivers flooding the winds beating down. We'll still have our share of ordinary life experiences that we somehow have to get through, but our house will not fall over, if it's built on the solid rock of Jesus. If instead, we base our lives on the shifting and changing world around us, the fashions and trends of our culture today, our foundation will be weak and we'll shift and change and crash.

## Prayer

This prayer is a responsive prayer. I'll read a line and then you all respond with the words: *'Help us to build our lives on you.'*

Jesus

When we listen to things that you've said

Help us to build our lives on you

When we want to know what to do next

Help us to build our lives on you

When we aren't sure what we should do

Help us to build our lives on you

When we want to ignore what we know is right

Help us to build our lives on you

When we want to walk away

Help us to build our lives on you

## Games: 10-15 minutes.

1. A noisy fun game to get girls into groups is to give them a card with an animal name written on it. They then have to make the animal noise of the animal written on their card as they move around the hall, locating the other members of their animal family.
2. Animal Tails - Equipment- bands or long strips of material. Tuck a strip of material into your shorts/skirt with the majority of the material hanging out like a tail. On the word "Go" try to get as many other tails from other players while protecting your own tail. Once you have acquired a new tail you must tuck that one into your shorts/skirt before you continue playing. The winner is the girl with the most tails.
3. A quieter guessing game is to put stickers on the backs of each girl with a different animal name. The girl has to go around the room asking other girls a question with the aim of identifying the animal on their label. The responses can only be Yes or NO. The first 5 girls can get points or prizes.
4. Catch the Dragon's Tail - Equipment - band or long strip of material. Girls are in groups of 6-8 lined up one behind the other - all hold onto the waist of the person in front. The back girl tucks a band into her shorts/skirt. On "Go" the front person in the line (DRAGON) chases its own tail i.e. the front person whose hands are free tries to snatch the band from the girl at the back. If the dragon catches its tail, the head person moves to the end and takes up the last position. The second person in the line becomes the new head. A variation on the game is where each group tries to catch the tail of another group.

**Badge Work:**

Show a model or the picture of the bird feeder or rabbit hutch the girls will be making in their groups. Explain the process of construction (5 minutes)

**20 Minutes**

Divide the girls into groups so some are working on making the bird feeders and the others are learning building techniques of hammering and sawing. Teach the girls how to use the tools correctly before letting them loose on scraps of wood.

Introduce the competitive element into this activity e.g. fastest to hammer a nail into a log of wood, least number of hits, straightest sawn log. Use points and prizes to reward.

**Clean up and sweep up - 5 minutes.**

**Guest Speaker- 20 minutes**

Introduce your visiting expert. Encourage the girls to ask questions at the end. Your guest may have brought along a pet, allow time for the girls to interact with the pet.

**Close the evening with Prayer**

**Notices & Home Time**

**Pre SetUp** - same as last week.

**Games** - have some more fun with last week's games.

**Usual SetUp.**

**Devotions:**

Using the Bible passages in *Genesis* on Creation and how God created all living creatures, and the story of Noah's Ark, use this devotional session to talk to the girls about the importance of caring for God's creatures and their responsibility to their pets.

**Message:** Pets teach children lessons but require time and devotion



A pet can teach children important life lessons, but parents must decide if their family has the time and devotion to raise one, parents may be amazed at the qualities children develop from owning a pet.

Whether it's a fish, bird, dog or cat, pets can help children develop lifelong character traits, such as responsibility, compassion, empathy and the ability to love unconditionally.

The unconditional love offered by a family pet can help children develop positive self-esteem. Children also can develop a sense of responsibility and confidence through caring for a pet.

Knowing a pet depends on him or her, helps develop a child's accountability and conscience. Caring children learn to bring a pet inside when the weather is bad. They learn that their pet depends on them to fill the water and food bowls. They learn that a pet left alone all day needs to romp and run with them when they get home from school.

Children can learn that pets need to be treated respectfully and that all living things have feelings. They learn that animals get hungry, thirsty and tired.

Like people, sometimes animals feel like playing, and sometimes they don't. Children also need to learn that pets can be scared by loud noises, just as they are sometimes scared by something unexpected. Though children are usually the receivers of care, having a pet puts the child in the position of caregiver. Children

learn to recognize and respond to their pet's needs, such as when the pet needs to be played with, fed or walked.

Key to creating a lasting family-pet bond is choosing a pet that fits into the family's lifestyle.

**Badge Work:**

Complete the building project.

Arrange another visitor to speak to the girls or the girls might like to bring along their own pet, be wary of pet chaos (cats and dogs together). They can talk about how they care for their pet - they become the expert on pet care. After a show and tell give plenty of "Pat a Pet time".

**Note:** You may choose to complete the building project in one week and have your visiting expert take a whole session the following week. This would certainly be advisable if the visitor is bringing along a pet and the girls want to hold, pat and cuddle the pet.

**Close the evening with prayer.**

**Notices & Home Time:**

Ensure you have well prepared notices regarding your trip day with time and place of meeting, recommended clothing and shoes, food, drinks etc.

**Trip Day - this may be better to be held on a Saturday**

**Depending on your location you may choose to:**

Visit a farm, or go Horse riding or help out at a Riding for the Disabled School. Girls love horses and this is a great opportunity to introduce them to horses in a safe environment. If your IFG group is located near a farm that breeds horses, pigs, chickens, alpacas, even ostriches, try to arrange a visit, you may offer to do some community service there as well.



Visit a DOC wildlife sanctuary e.g. Tiritirimatangi Island in the Hauraki Gulf or Regional Park.

Contact DOC about when and where they are releasing chicks back into the wild.

Visiting a farm - helping to round up sheep, watching milking and assisting where possible - even hand milking a cow, are all memorable experiences for girls who have had little or no experience on farms.

Other farm related activities: eeling, quad bike riding on a farm or mud slides.

***Please complete the necessary RAMS forms and notices home informing parents of your upcoming outing. Inform the girls on necessary clothing and footwear for this trip.***



## How to make a bird feeder



### Tools

Jig saw  
 Drill/driver with bits and bits  
 Screwdriver  
 Hammer and nail set  
 Clamps (1 1/2" capacity)  
 File and Sandpaper  
 Dust mask  
 Goggles  
 Hearing Protection

### Materials (*Note - metric measurements below*)

1 x 2 boards rated for outdoor use

12 1/2" (1)

8 1/4" (2)

8" (2)

3" wide PVC drain pipe 11" long cut 140° segment

5/16" dowel by 12 1/2" long x 4

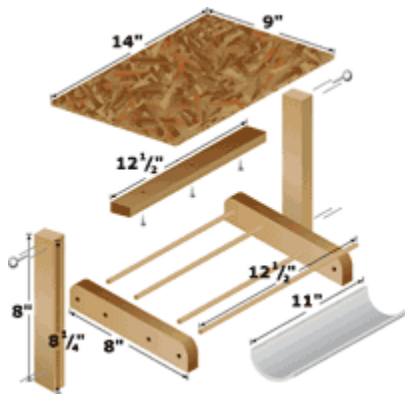

1/4" thick oriented strand board or weatherproof plywood, 9" x 14"

1" screws (3)

1/2" screw eyes (2)

1 1/2" brads (4)

Wood glue

Paint

(optional)

3/8" rope (3')

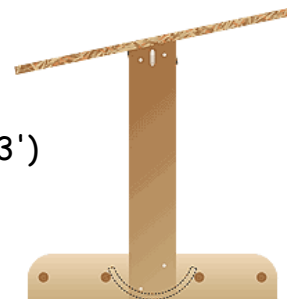

Your final bird feeder should look like this from one end. The pipe is hidden from view.

1. Cut PVC pipe to length. Use the jigsaw to cut a 140° segment File and sand.
2. Saw roof to 9" x 14".
3. Saw 1 x 2 pieces to shapes and sizes shown.
4. Drill pilot holes for brads, screw eyes and screws. Countersink screw holes.
5. With the base pieces clamped together, drill holes for dowels.
6. Glue 1 x 2 strut under roof and attach with 3 screws.
7. Glue 1 x 2 side pieces to base pieces and attach with brads and clamps until dry.
8. Attach tops of 1 x 2 side pieces to roof and ends of roof strut with glue and brads.
9. Install screw eyes.
10. Cut dowels to length to match assembly and install in holes in base pieces.
11. Paint roof, if desired.
12. Place pipe segment between central dowels.
13. Tie rope to screw eyes for hanging.

**Note:**

*'The Build a Bird Feeder' plans are measured using imperial measurements. The following list is the approximate metric conversions.*

*Roof - weather proof plywood 9"x14" (225mmx350mm)*

*Alternative materials for the roof: melamine shelving or even corrugated plastic that Real Estate Agents use for their signage.*

*Measurements for the wood: Wood needs to be H1 treated wood*

*12 ½" (300mm)*

*8 ¼" (206mm)*

*8" (200mm)*

*PVC 100mm cut into 1/3*

*5/16" dowel ( use 7mm need about 1.2m)*

*12 ½" long (300mm)*

*Brads - nails (use galvanized nails 35mm)*

*Wood glue - don't use PVA*